

EMMERITO

Global Canning Expertise

Watch our Institutional Video



[Menu]



This is a dynamic catalogue, you can use the arrow keys to navigate.

Food Technology since 1.964

EMERITO offers its customers a wide experience in **technological solutions for food packaging** in **rigid containers** (cans, jars, bottles, etc.) with the idea of obtaining the highest quality in their processes, optimizing at the same time the resources and the cost of them. And it does so with the utmost respect for the environment.

More than 3,500 m2 of production facilities

In-house engineering

International quality certificates



More than 1,000 machines on 5 continents



[Menu]



This is a dynamic catalogue, you can use the arrow keys to navigate.



Catalogue

Complete Lines	Page 4
Depalletizers	Page 8
Empty Containers Rinsing Systems	Page 9
Filling Systems	Page 10
Twist Off & PT Capping Machines	Page 19
Vacuum Detectors	Page 33
Rotary Head Spacers	Page 34
Baskets Loading Unloading Systems	Page 35
Washing & Drying Systems	Page 36
Additional Equipment	Page 40

[Menu]



This is a dynamic catalogue, you can use the arrow keys to navigate.

OFICINA TÉCNICA
TECHNICAL OFFICE

MM
emerita.com

MM
emerita.com

MM

Complete Canning Lines

[Menu]



Complete Lines

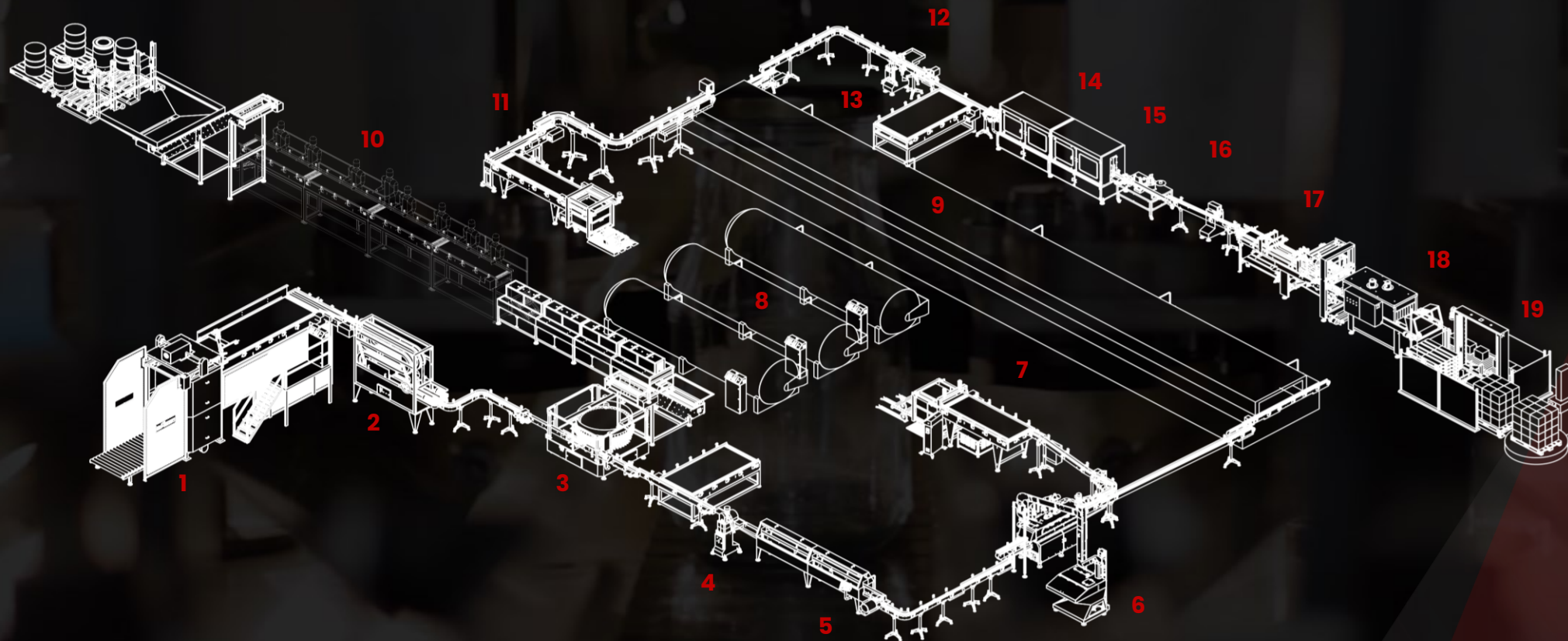

- | | | | | |
|----------------------|-----------------------------|----------------------------|-------------------|-------------------|
| 1 Depalletiser | 5 Liquids Filler | 9 Pasteurizer | 13 Table | 17 Case Packer |
| 2 Rinsing System | 6 Twist Off Capping Machine | 10 Manual Work Tables | 14 Washing System | 18 Shrink-wrapper |
| 3 Solids Filler | 7 Baskets Loading Syst. | 11 Baskets Unloading Syst. | 15 Dryer System | 19 Palletiser |
| 4 Rotary Head Spacer | 8 Retorts | 12 Vacuum Detector | 16 Labeler | |

[Menu]



Complete Lines
Sauces

Operative Sample

Sauce Line

+ Info
▶ Video

Rotary Plate (accumulation)

Full Containers Drying Syst.

Vacuum Detector

Empty Containers Rinsing Syst.

Full Containers Washing Syst.

Capping Machine

Sauces Filler

Rotary Plate (feeder)



Start Of The Line

[Menu]



Go Back to Complete Lines

Depalletizers

Depalletizers

Jars | Cans | Bottles

Different degrees of automation available

Machines designed to depalletize rigid empty containers such as jars, cans or bottles, which are already palletized, with the function to align them one by one and to correctly convey them to the canning line. It can also be used at the end of the line with full containers to align them one by one and lead them to the batch marking and labeling area.

We offer alternatives to depalletize also plastic containers, according to formats and production range, always after studying the particular application.

Depalletizing systems by Cartesian Sweeping, layer by layer, in addition to including accumulation table and its output belts at different speeds to place the containers in line, one by one.

We have some options to automate our depalletizing systems to the maximum, such as:



- Automatic pallet loading system prior to depalletizing, with capacity to accommodate 2 pallets in waiting and one additional pallet in loading.
- Automatic removal system of separators between layers, which also includes a stainless steel cage to accumulate them in a controlled way during the work.
- Automatic output of empty pallets.



SMA - 250

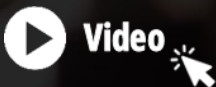

SMA - 500

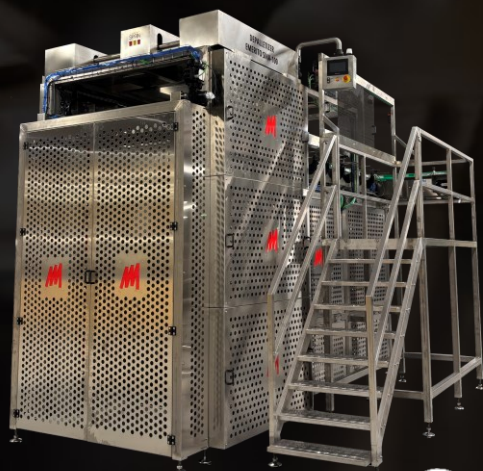
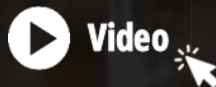

SMA - 100



SMA - 100

SMA - 250

SMA - 500

Containers

Jars, cans, PET, bottles, etc.

Capacity

1 layer / min.

2,5 layers / min.

5 layers / min.

Complements

Automatic carton layers removal.

Automatic carton layers removal.
Second pallet automatic charge.
Containers unloading - blowing system. 8

[Menu]



Go Back to Complete Lines

Empty Containers Rinsing Syst.

Rinsing System
For empty containers

Water

Air

Steam

This machine is designed specifically to carry out the cleaning of empty containers used in food production processes, even if they are made in plastic, tin or glass.

The containers washing machine, which is built mainly in first quality AISI 316L steel, automates the washing of containers without the need of adding additional tools, thus achieving a significant improvement in production capacity as well as an efficiency in the use of personnel, which means an immediate improvement of competitiveness.

The nature of the materials used in its manufacture, together with the unquestionable quality in manufacturing finishes, makes this machine an instrument for reliable and long lasting to help extend life even in situations of more demanding and committed work.



Video



Info



U2



Universal



U1

U1

U2

U2 - SP

Universal

Containers

All formats

Capacity

Up to 40 containers /min.

Up to 150 containers /min.

Up to 200 containers /min.

Up to 600 containers /min.

Versatility

Need of formats shapes confirmation.

All containers without installation of additional elements.
Easy format change adjustment by opening lateral belts.

All containers without installation of additional elements.
Easy adjustment for the change of different formats.

[Menu]

Go Back to Complete Lines



Filling Systems

[Menu]



Go Back to Complete Lines

Filling Systems

Solids



Linear Overflow + Vibration

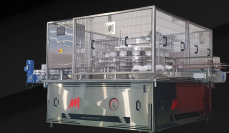

Volumetric Rotary Telescopic

Liquids



Waterfall | Cascade



Level Control



Under Vacuum

Sauces



Piston Volumetric



Volumetric | Flowmeter



Linear Overflow + Vibration

Adaptable to any process

Easy maintenance

Robustness



LS 2M

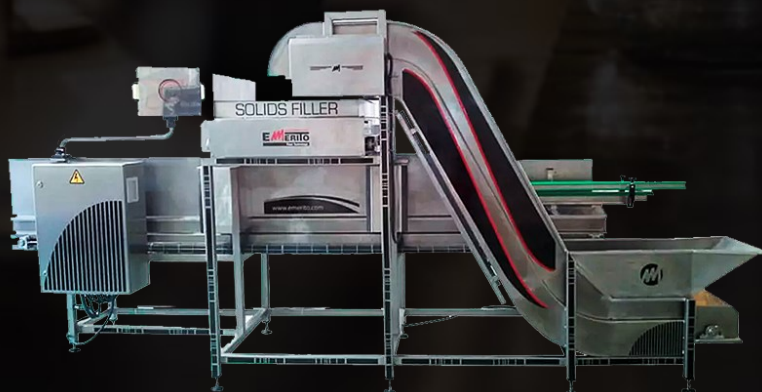

LS 1.5M



Machine designed for filling solids by overflow that it incorporates a vibration system of containers at the exit of the machine that removes the excess product (brim) from the mouth of containers, returning them again to the ramp of filling through a return conveyor.

This filler it's very simple and easy to maintain, that adapts perfectly to different ranges or levels of production, products and containers, according to the needs of each client.

Despite its simplicity, Emerito maintains in this equipment the highest quality standards, both in materials and electronic components, with the fundamental premise of providing this equipment with a special robustness and durability even in the most demanding working conditions.



LS

RS

Technology

Linear Overflow + Vibration.

Telescopic.

Capacity

Up to 250u. / min.

Up to 600u. / min.

Products

Solids | Laminates | In cubes.

Volumetric Rotary Telescopic Filling Machine

Adaptable to different types of formats

Volumetric control through telescopes



This filling machine can adapt different technologies to the filling of different types of solids, covering a wide range of possible applications.

Filling through telescopic glasses which allow to regulate the quantity to fill depending on the ranges of containers or product type to dispense, medium and high speeds.

This filler can adapt different technologies to the filling of different types of solids, covering a wide range of possible applications.



RS

LS

Technology

Telescopic.

Linear overflow + vibration.

Capacity

Up to 600u. / min.

Up to 250u. / min.

Products

Solids | Laminates | In cubes.



Waterfall | Cascade

Simplicity of Operation

Total Adaptability



Machine designed for the dosing of control liquids by means of an overflow or cascade system, easily adaptable to different production ranges and container formats.

Our overflow dosing system is a simple and economical solution for the dosing of liquids, whether it is brine, water, vinegar, oil or any of the most frequently used liquids in the manufacture and canning food. Despite its simple operation, we have not underestimated the quality of the materials and finishes, both elements that identify all Emerito equipment and that also reach all the commercial components that we include in its manufacture, always using the leading brands in the market.

Our overflow liquid dispenser allows us to easily adapt to the production requirements of each customer, making the equipment fit perfectly into the manufacturing process, taking care of every detail to the maximum to allow precise control of the filling as well as the head space.

Our cascade dosers allow to control the filling temperature and to make a perfect recirculation of the liquid in order to achieve its maximum utilization by using a double filtering process to avoid the loss of quality of the liquid.



Filling Systems
Liquids

Level Control

Fiber Optic Control

Avoidance of risk of solid oxidation

Filling machine for covered liquids (oil, vinegar, brine, water) controlling with perfect accuracy the established level of the liquid to be filled.

Regardless of the amount and volume of solid product containing each container, the liquid always reaches a same level favoring the homogeneity of the space head and logically the range of vacuum that is achieved in each of the containers, even bringing solid liquid penetration time in the solid part which this is more complicated (as for example in the case of canned tuna with oil).

This level control filler is intended for those producers who want to emphasize the quality of its processes, this system equipped with sensors that receive and send signals through fiber optic, avoids the spillage of liquid to the outside of the container, so it gets a clean working environment and the necessary maintenance is reduced considerably.

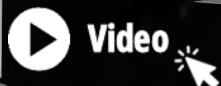
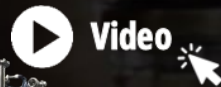

Linear T + N

Rotative Rota + N

Technology

Filling by level control.

Capacity

Up to 50u. / min.

Up to 100u. / min.

Products

Covering liquids (oil, vinegar, brine, etc).



Under Vacuum

Better Penetration of Liquids into the Product

Clean environment



Machine designed in rotary versions for the filling of covered liquids (oil, vinegar, brine, water) with technology "under vacuum". This technology is usually aimed at medium and large producers as the increase of speed in the filling of liquids in the rotary versions, is considerable.

Filling "under vacuum" technique allows us to, on a single machine, proceed to the extraction of the air occluded in the inter-spaces that may have the solid product containing in the containers, prior to fill the liquid, creating a homogeneous vacuum within each container. This means that while the filling of liquid, is done in a controlled vacuum atmosphere, which facilitates this penetrate properly into the holes left by the product as it happens when you package, for example, canned fish, meat, or vegetables. This is, without a doubt, an improvement in the quality of the packaging because it allows us to control accurately the head of container space, at the time that we avoid spillovers that can adversely affect the quality of the packaging.

With this system, we achieve the highest quality in completion of the product and what is equally important, got that its presentation in the market is perfect.

+ Info

RVB

Technology

Rotary Vacuum Filler.

Capacity

Up to 600u. / min.

Products

Liquids and low-density sauces "Under Vacuum".

Piston Volumetric

Low & High Densities

Temperature Control | Level

Machine designed to fill sauces or liquid by volume control, regardless of the density either high or low.

This equipment is used frequently for the filling of jams, yogurt, honey, pates, sauces and purées and even mixtures that may contain solid particles, provided that the mixture is homogeneous.

Our piston dispensers are equipped with a main tank that, under the free choice of the customer, can be complemented with different options depending on each application or product to work: product temperature control, agitator-mixer to maintain the homogeneity of the mixture, or an integrated pumping system, with control of maximum and minimum levels, to perform an automatic and controlled supply of the product to our tank.

The volume of the filling piston (standard 600cm³) is adjusted by means of a handwheel with counter, which allows us to easily and quickly regulate the different filling quantities with exquisite precision.

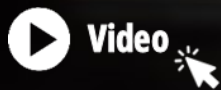

1C - 2C - 3C - 4C - 6C | 4C-A | 6C-A (Alternative)

Technology

Volumetric Pistons.

Capacity

From 10 up to 120 cpm.

Products

Liquids, sauces and even mixtures that may contain solid particles.

Volumetric | Flowmeters

Magnetic Mass Flowmeters

Linear & Rotary versions



Machine designed in linear and rotary versions, adapted for the filling of sauces, pastes or liquids, regardless of the density either low or high, by flow control (volume).

In this case the technology that is used for the filling of containers is the flowmeters, being mass or magnetic, which are determined depending on the characteristics of each application in particular.

This equipment can be measured in mouths of filling, according to the requirements of the customer to get adapted to his production needs.

It also includes a pressurized tank that, depending on the demand of each customer, can be complemented with different optional elements such as product temperature control, an agitator-mixer to maintain product homogeneity, as well as maximum and minimum level controls to adjust the pumping rate of the product either from the preparation areas or from intermediate tanks manufactured for this purpose.



2FM, 4FM, 6FM,
4FM-A, 6FM-A

RFM

Technology

Lineal Filling
(flowmeters).

Rotative Filling
(flowmeters).

Capacity

From 10 to 120 u/min.

Up to 600u. / min.

Products

Líquidos, salsas, productos pastosos de alta y baja densidad en general.



Twist-Off & PT Capping Machines

[Menu]



Go Back to Complete Lines

Twist Off & PT Capping Machines

The widest range of capping machines for glass and PET
Types of Closures:

Twist Off

PT



Emerito 0.8



Emerito Series 1.8



Emerito Series 2.8



Emerito Series 3.8 y 5.8



Emerito 4.8

Types of lids

Comparative Table

ACT System

+ Info

Capping Machines
Twist-Off & PT

Emerito 0.8

Capacity: 20 cpm

Automatic



Automatic glass bottle capper suitable for laboratory work or for producers who handle few formats of bottles and lids with Twist Off and PT system. In the case of PET bottles with Twist Off lids, the quality of the work of this equipment will depend directly on the quality of the PET format to be used in it.

This equipment works by means of a rotary transport system of containers inside and with a closing head adapted to the corresponding cap diameter using the so-called BC-“Balanced Capping” technology.

Optionally, it incorporates a steam management system that we receive from the boiler already existing in the factory, to facilitate the generation of a safety vacuum by injecting it into the head space of the container prior to closure. This steam management system also includes the corresponding module for the extraction of excess steam during the capping process.



Lids
Diameter: from T038 to T082
Height: up to 18 mm (DTO)



Containers
Diameter: from 30 mm to 106 mm
Height: from 40 mm to 260 mm

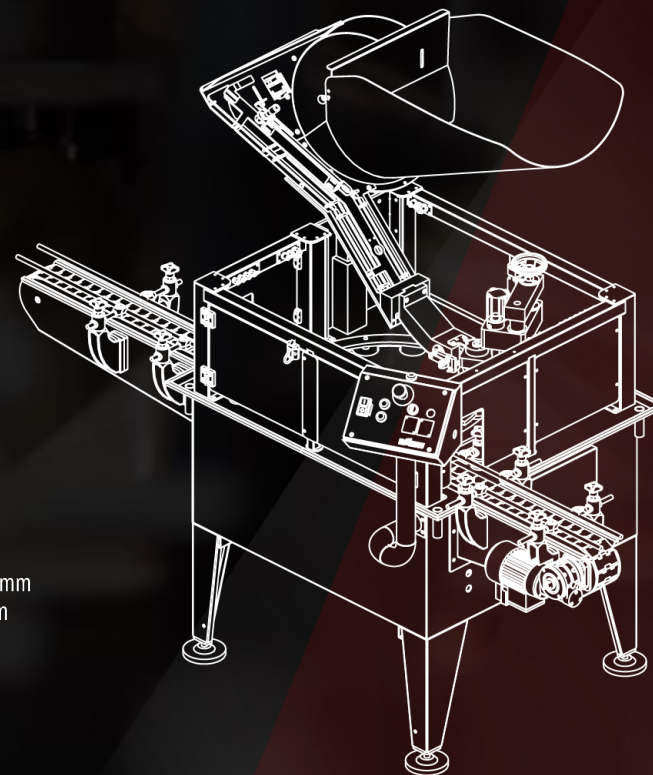

Series Emerito 1.8

Automatics



Emerito 1.8



Lids

Diameter: from T038 to T082 or T0110* (Emerito 1.8 G*)
Height: up to 18 mm (DTO)



Containers

Diameter: from 30 mm to 106 or 160* mm (Emerito 1.8 G*)
Height: from 40 mm to 260 mm

Standard Versions

70 units per minute | 4.800 units per hour

ACT Versions (for oil & greasy substances)

50 units per minute | 3.000 units per hour



Emerito 1.8 G

Total versatility of packaging and formats

Enlargement of frame and capping basin

+ Info

Series Emerito 1.8

Standard Components

- Automatic cap feeding hopper.
- Cap presence – absence detectors in the feeder.
- Exclusive “cap pre-curling control” system on the pre-closing assembly.
- Liquid collection tray with perimeter channel to convey liquids to centralised outlets (cooling water, cleaning, spillage, etc.).
- Dynamic elements synchronised by means of frequency variators.
- Centralised electrical and control panel, separate from the machine and connected via HARTING connection.
- Motorised regulation for change of format height.
- Variable speed drive with potentiometer controlled from the control panel.

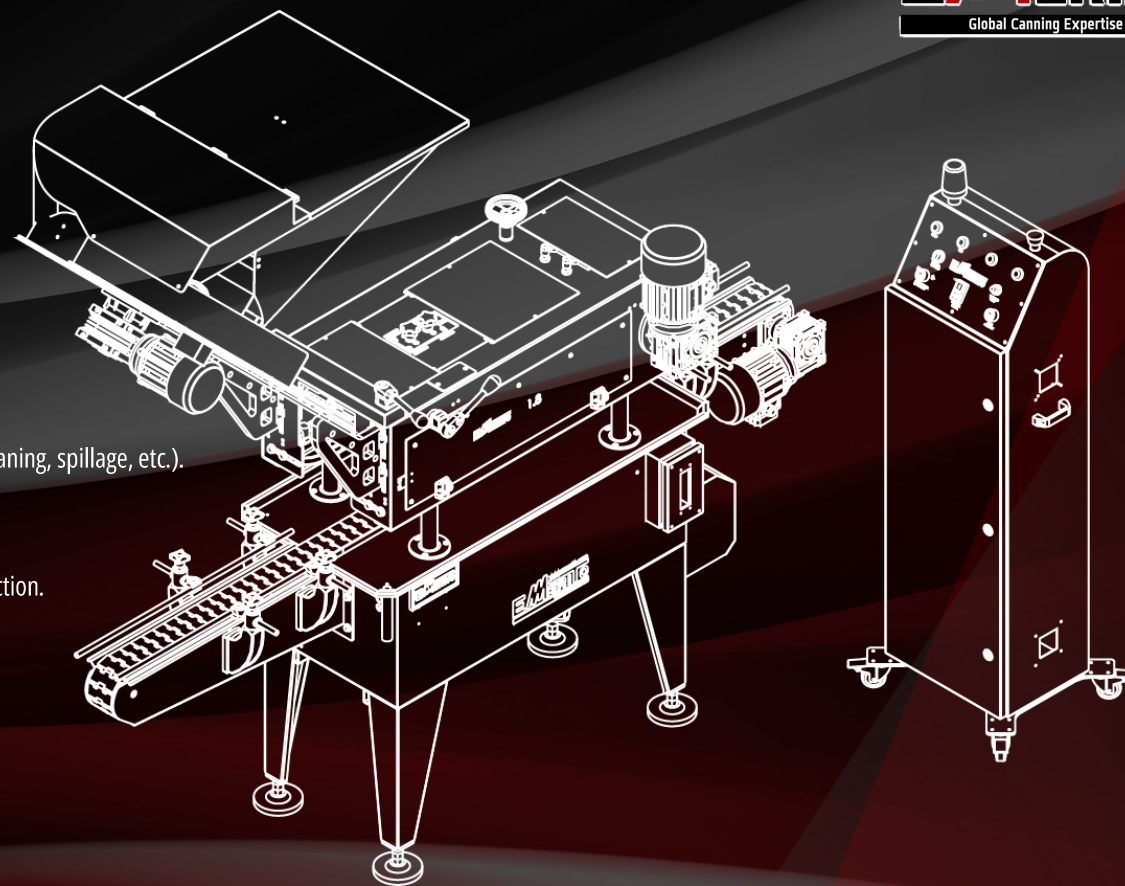

Options

Connection to supply and/or storage plate

Lateral traction for container transport, with double belt.

Steam management system for preheating the lids and injecting steam into the equipment, which facilitates the creation of the safety vacuum.



Capping Machines
Twist-Off & PT

Series Emerito 2.8



Automatics

Medium – High Productions



Lids
Diameter: from T038 to T0110
Height: up to 18 mm (DTO)



Containers
Diameter: from 30 mm to 160 mm
Height: from 40 mm to 260 mm

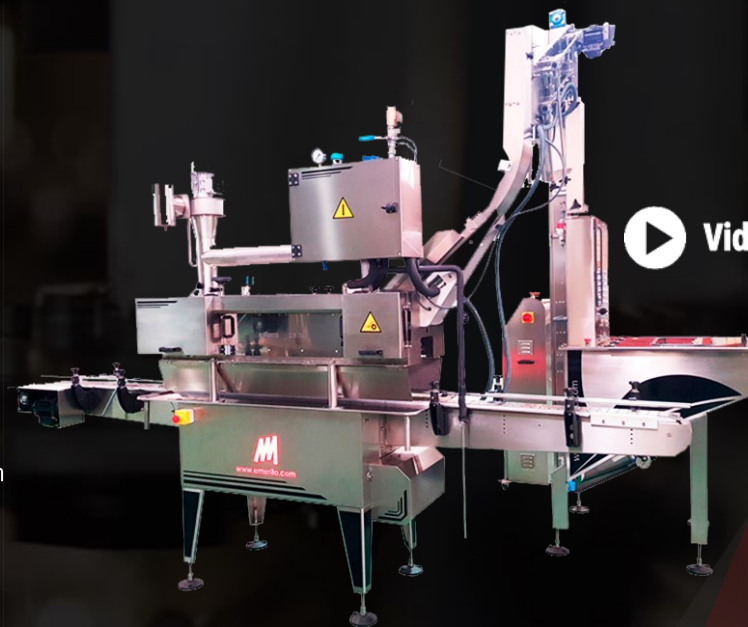

Emerito 2.8

Emerito 2.8 SP

Automatic Container Format Changeover

Emerito 2.8 SM

Emerito 2.8 M2

Standard Versions

130 units per minute | 7.800 units per hour

ACT Versions (for oil & greasy substances)

110 units per minute | 6.600 units per hour

Standard Versions

200 units per minute | 12.000 units per hour

ACT Versions (for oil & greasy substances)

170 units per minute | 10.800 units per hour



[Menu]



Go Back to Complete Lines

Series Emerito 2.8 Standard Components

- Automatic lid feeder by magnetic column.
- Lid positioner by mechanical selector.
- Lid presence-absence detector in the feeder.
- Easy system for caps removal in hopper.
- Minimum level signal of caps in hopper.
- Universal caps drop, valid for all caps sizes.
- Exclusive “pre-lid screw-on control” system in the presclosing assembly.
- Fitting for steam inlet to pre-heat the lids and facilitate the safety vacuum.
- Liquid recovery tray (cooling water, overflows, etc.).
- High-end motorised headstock for changing format height.
- Dynamic elements synchronized with inverters.
- Independent and centralised controller.
- Lateral belts regulation from central steering wheel.
- Adjustable height from control panel.
- Side pressure bands for container transport.

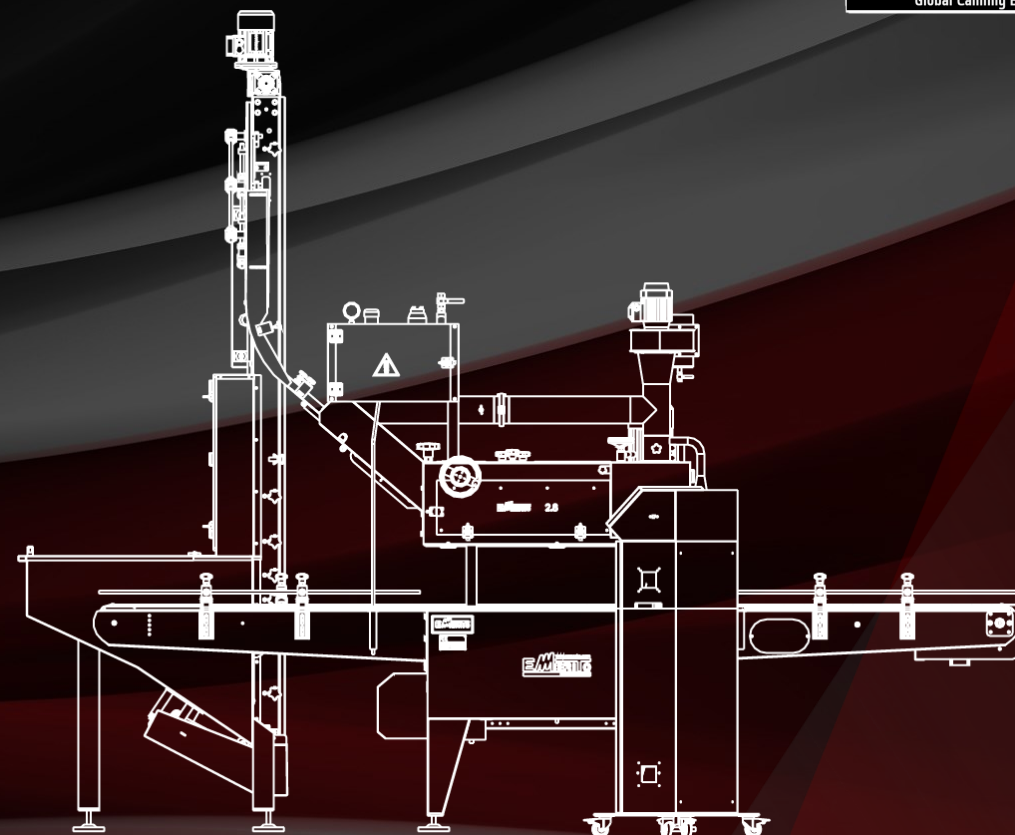

Options

Connection to supply and/or storage plate

Lateral traction for container transport, with double belt.



Steam management system for preheating the lids and injecting steam into the equipment, which facilitates the creation of the safety vacuum.

Capping Machines
Twist-Off & PT

Series Emerito 3.8 & 5.8

Automatics

Automatic Container Format Changeover

High Capacity



Video

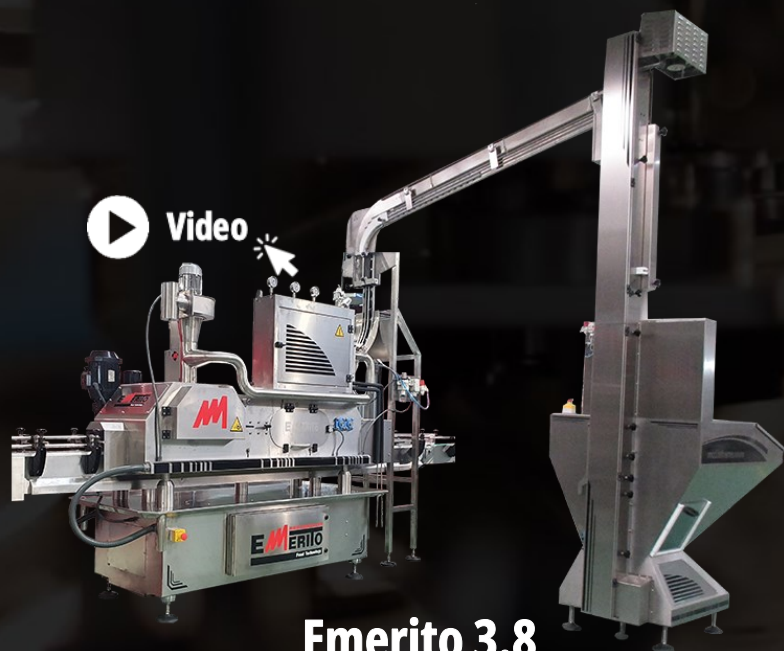

Emerito 3.8

Standard Versions

330 units per minute | 19.800 units per hour

ACT Versions (for oil & greasy substances)

300 units per minute | 18.000 units per hour



Lids

Diameter: from T038 to T0110
Height: from 18 mm (DTO)



Containers

Diameter: from 30 mm to 160 mm
Height: from 40 mm to 260 mm



Video



Emerito 5.8

600 units per minute | 36.000 units per hour



Info



Series Emerito 3.8 y 5.8 Standard Components

- Automatic lid feeder by magnetic column.
- Lid positioner by mechanical selector.
- Lid presence-absence detector in the feeder.
- Easy system for caps removal in hopper.
- Minimum level signal of caps in hopper.
- Universal caps drop, valid for all caps sizes.
- Exclusive “pre-lid screw-on control” system in the preclosing assembly.
- Fitting for steam inlet to pre-heat the lids and facilitate the safety vacuum.
- Liquid recovery tray (cooling water, overflows, etc.).
- High-end motorised headstock for changing format height.
- Dynamic elements synchronized with inverters.
- Independent and centralised controller.
- Lateral belts regulation from central steering wheel.
- Adjustable height from control panel.
- Side pressure bands for container transport.

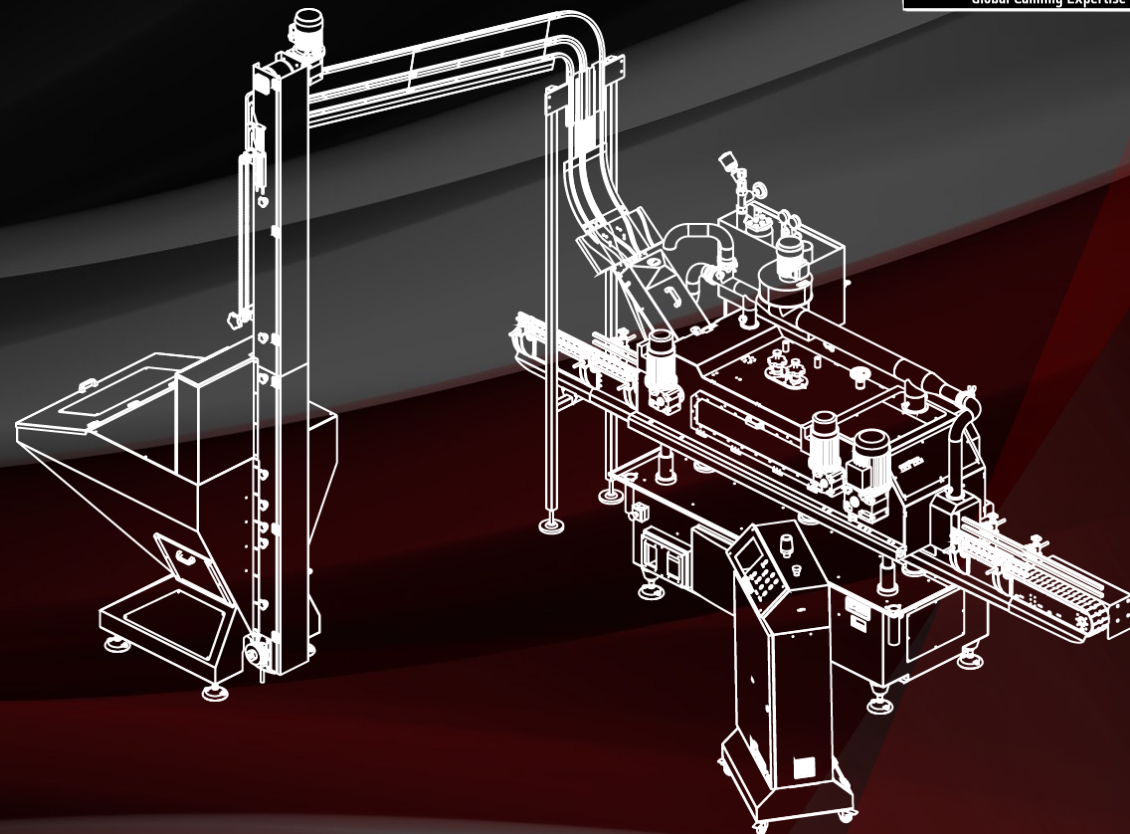

Options

Connection to supply and/or storage plate

Lateral traction for container transport, with double belt.



Steam management system for preheating the lids and injecting steam into the equipment, which facilitates the creation of the safety vacuum.

Capping Machines
Twist-Off & PT

Emerito 4.8

Capacity: 40 cpm

Under Vacuum System

Machine designed for closing glass jars with Twist Off and PT type closing system that require no humid atmosphere inside. Mechanical vacuum system to process products that do not tolerate humid environments.

Our capping machine has independent and adjustable positioning of all the mechanisms involved in the closure, giving it a very high working reliability. It is made of stainless steel, with a very robust appearance. Its outer chamber is also made of stainless steel, 12 mm thick. The total weight of the equipment exceeds 2,500 kg.

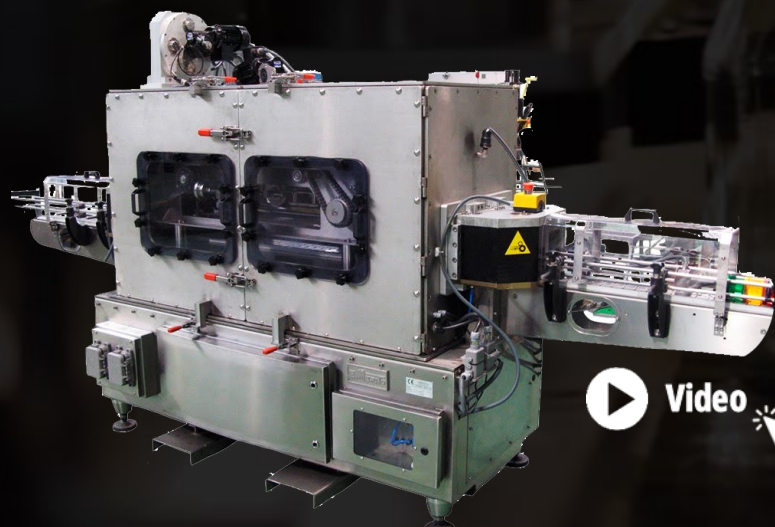

 **Video**



Lids

Diameter: from T043 to T082
Height: from 18 mm (DTO)



Containers

Diameter: from 45 mm to 105 mm
Height: from 50 mm to 200 mm

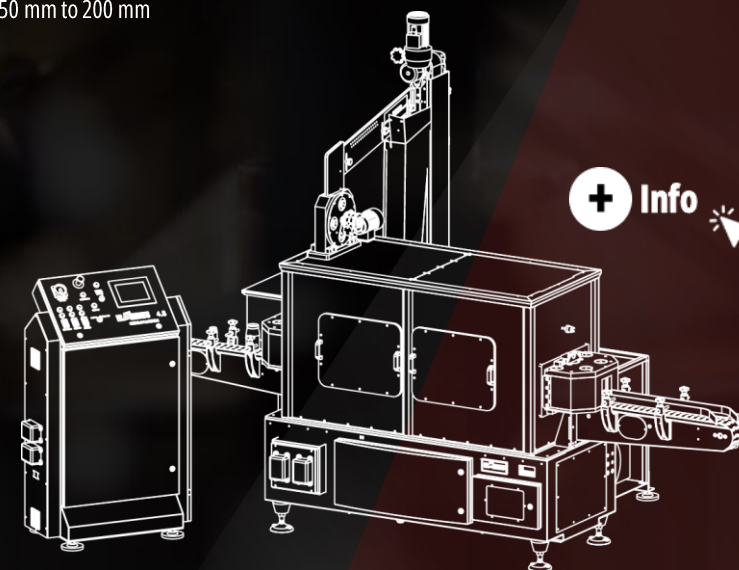

 **Info**

Types of lids

RTO – RTS - FTO – FSO – MTO – DWO – RTB – RSB – FTB – FSB – MTB – DWB

Diameter: from T038 to T0110

RTO: Flat Twist-Off Lids

RTS: Twist-Off Lids with stepped design

FTO: Twist-Off Lids with crenellated rim

FSO: Twist-Off Lids renellated with step

MTO: Normal lid with half waist

DWO: Normal lid with high waist

RTB: RTO with safety button

RSB: RTS with safety button

FTB: FTO with safety button

FSB: FSO with safety button

MTB: MTO with safety button

DWB: DWO with safety button

Capping Machines
Twist-Off & PT

ACT System (Antislip Chain Traction)

Solutions for oil or other greasy substances

The experience of so many years in the market has allowed Emerito S.L. to develop tools adapted to the needs that arise in the different areas of packaging. Among them, the ACT System (Antislip Chain Traction) stands out. This Antislip Chain Traction guarantees 100% of the work of our capping machines even in the worst working environments and even when the containers may be completely impregnated **with oil or other greasy substances**.

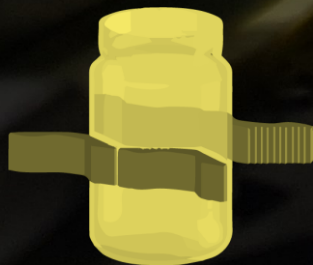

Capping Machines
Twist-Off & PT

Comparative Table

Models	Capacity	Automatic Container Format Changeover
Emerito 0.8	20 u./min.	No.
Emerito 1.8	70 u./min.	
Emerito 1.8 ACT*	50 u./min.	
Emerito 1.8 G	70 u./min.	
Emerito 1.8 G ACT*	50 u./min.	
Emerito 2.8	130 u./min.	
Emerito 2.8 ACT*	100 u./min.	
Emerito 2.8 M2	200 u./min.	
Emerito 2.8 M2 ACT*	170 u./min.	
Emerito 2.8 SP	130 u./min.	
Emerito 2.8 SP ACT*	100 u./min.	
Emerito 2.8 SM	200 u./min.	
Emerito 2.8 SM ACT*	170 u./min.	
Emerito 3.8**	330 u./min.	
Emerito 3.8 ACT* y **	300 u./min.	
Emerito 5.8**	600 u./min.	
Emerito 4.8	40 u./min.	No.

Capping Types

Complements & Versions

Steam injection + extraction (optional).

Steam injection + extraction (optional).

*** ACT system** for containers with oil or slippery substances on the outside (optional).

Complete motorization for adjustment to different formats (optional).

Pneumatic lid elevator.

***ACT system** for containers with oil or slippery substances on the outside (optional).

****Complete motorization as standard.**

Mechanical vacuum.

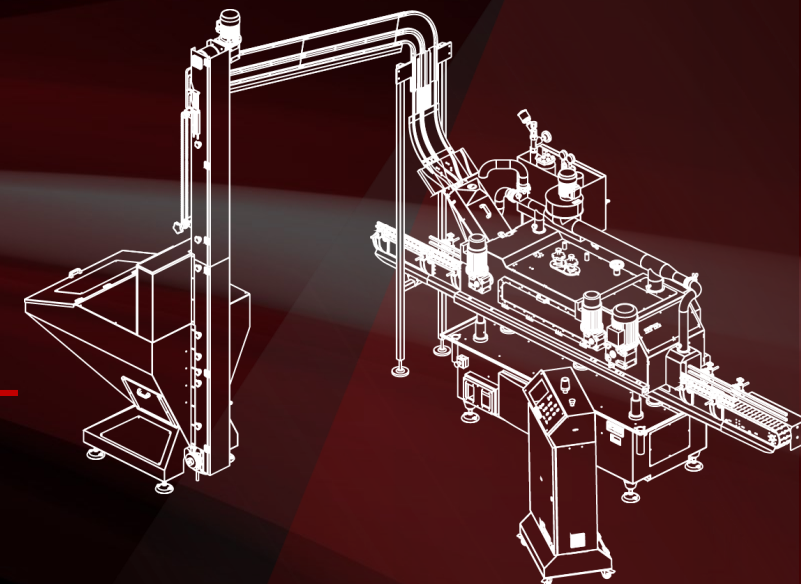
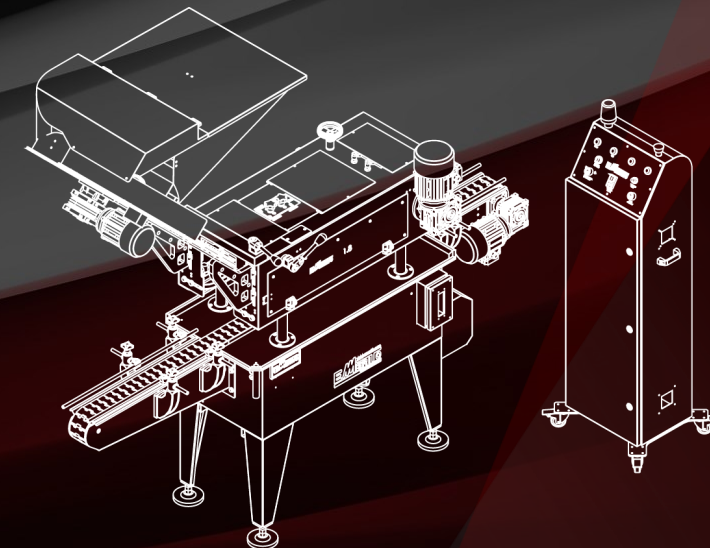



Line Complements

[Menu]



Go Back to Complete Lines

Vacuum Detectors
Line Complements

Vacuum Detectors

Emerito DVI 400

Improperly sealed containers | Without lids | Dented Cans

Food Safety



The vacuum detector is a fundamental equipment in terms of food safety. It is designed for quality control in food canning lines and works by checking the existence of vacuum inside the containers, as well as the correct positioning of the lid and the presence or absence of the same. In addition to ejecting from the line the containers without vacuum, it avoids the continuation of the process those containers that are not properly closed or without a lid, thus ensuring that they do not generate problems in the subsequent heat treatment part.

Placed in the part before labeling, we will avoid that any container without safety vacuum can be stored or taken to the market.

The expulsion of the incorrect containers is done to a reject tray or in case of high speeds to a conveyor or dynamic table in parallel, which Emerito S.L. offers as a complement if necessary. We also offer as an option a hinged belt where the equipment can be placed if the customer requires it or in case of not having a sufficiently stable belt for the correct reading of the parameters.

The software that incorporates our vacuum detector (developed completely by EMERITO), allows you to generate different types of notices or both audible and visual alarms and schedule them conveniently to have controlled the range of failures all the time.

+ Info

[Menu]



Go Back to Complete Lines

Rotary Head Spacers

Avoid overfilling (Colmo)

Facilitates Closing

Adaptable to any speed

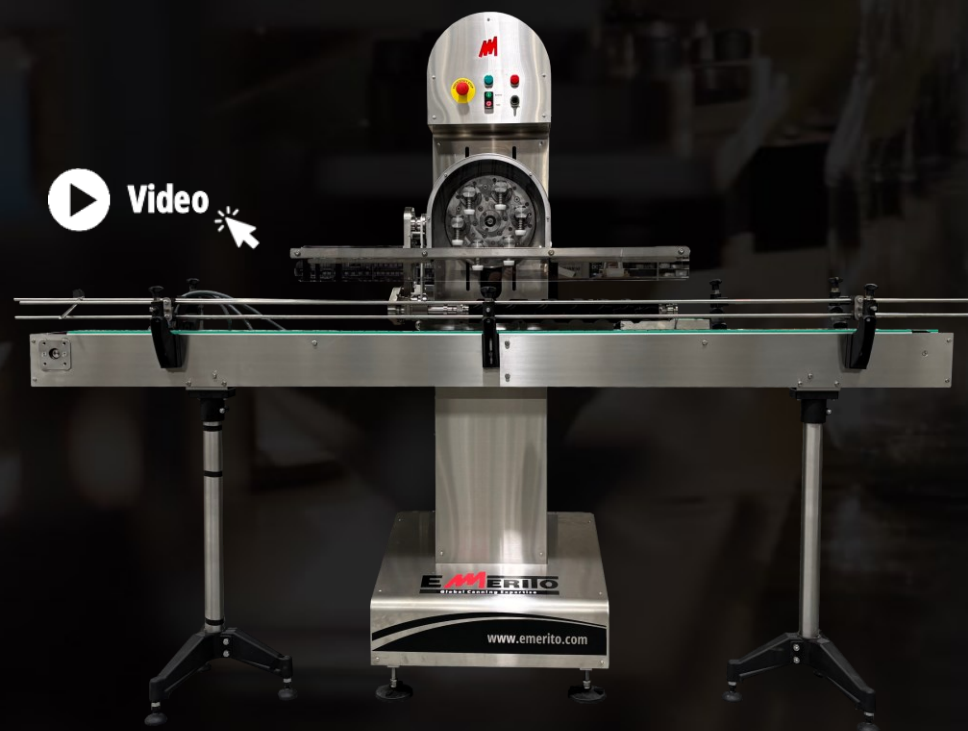

Machine designed specifically to avoid overfilling of solid product in containers before being closed, pushing it inside in a controlled manner to achieve the objective.

This machine is essential to facilitate the capping of containers in which the product sticks out the mouth of the container, generating a brim that make difficult the action of closing or limiting the necessary head space for a correct range of security vacuum.

The pressure of the product is carried out in a way in which you can set us on many levels, avoiding damage to delicate products, through the use of a few plugs appropriate to the mouth of the container dimension, they can be graduated to be adapted to all the possible scenarios.

The Head Spacer can work in any line speed and is a versatile equipment in terms of products and canning formats.



Baskets Loading/Unloading Systems

Used in horizontal retorts

Automatics & Semiautomatics

Wide versatility

Machines designed to load and extract containers already closed in the baskets used in usual autoclaves. They can be automatic or semiautomatic, according to the needs that requires each canning line.

We are able to adapt to any size basket and container used. We also adapt to the extent of basket or brand of autoclave that exist in each project.

This machine uses hydraulic scissors or pneumatic cylinders for proper placement of each layer of containers in the baskets. We can offer options in versions with magnetic or pneumatic plates according to each need.



B. Loading Syst.

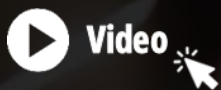

B. Unloading Syst.

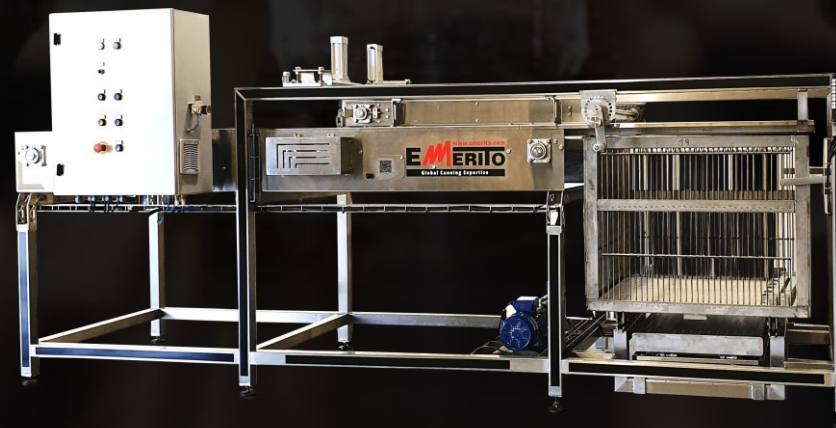



Washing & Drying Systems

[Menu]



Go Back to Complete Lines

Washing & Drying Syst.
For full containers

Full Containers Washing & Drying Systems

Full & Closed Containers

Cans | Bottles | Jars

Adaptable to different speed productions



Full Containers Washing Syst.



Full Containers Drying Syst.

[Menu]



Go Back to Complete Lines



Info

Washing Syst.
For full containers

Full Containers Washing Syst.

This washer is designed for the washing of full and closed containers. We can adapt specifically to the needs and applications of each customer, whether they work with cans, bottles, etc. of different formats.

Our full container washers, in order to improve the finishing quality and especially when soap is used, incorporate as standard a rinsing module that, if desired, can act independently. If the customer does not wish to use this independent system, simply by managing the shut-off valves, the module is incorporated into the general rinsing system. This rinsing module, in order to economize the use of mains water, acts only if it detects the entry of containers into the equipment. Otherwise, it stops working.

It is important to bear in mind that our full container washers are designed to work in continuous production, not to wash previously stored containers where dirt may have adhered.



[Menu]



Go Back to Complete Lines

Drying Syst.
For full containers

Full Containers Drying System

Dryer specifically designed for the drying of filled containers, developed for each customer according to the scope of application and taking into account, among other parameters, the required production speed, the container formats to be dried, as well as the drying time required to complete a high quality drying. With our dryer, which uses high-pressure drying technology, the customer can either store the containers in perfect conditions and without the risk of oxidation of the lids if continuous labeling is not carried out, or continue the continuous labeling process without traces of moisture that could complicate it.

In the manufacture of this equipment we use the most advanced components and drying systems in the market and we incorporate different elements that allow us to carry out a correct drying even in the most complicated areas of the containers, especially under the lids, to avoid later oxidation problems. Special care is also taken in the drying of the bases and body of the containers, regardless of their shape and size. In addition, the equipment has a high degree of soundproofing during the whole time it is in operation.



[Menu]

Go Back to Complete Lines

Additional Equipment



Rotative Plates



Tables



Hinged Tapes



Electric Steam
Generators

+ than 60 years of experience behind us

**We introduce you to the best partners in the world
to help you with your needs**

**Principle of the line
Product preparation**

From washing the product to cooking it.
We help you by putting you in contact with the best
specialists in the world.

Canning Process

Emerito S.L. is the worldwide reference for
the packaging of your product.

PET

If you pack in PET format with plastic lid, we
help you to find your solutions.

End of the Line

From pack formation and shrink wrapping to robot
palletizing of the finished product.



Our After Sales Service Platform

M Care is the new digital platform through which every customer, regardless of where they are in the world, can manage spare parts for any of our equipment and coordinate any technical assistance service they may require. With this tool we want to make easier the intercommunication with our customers allowing the exchange of information that will help to save any inconvenience that may arise in the day to day. Photos, videos, instant chat service. **M Care** is, in short, **being closer to our customers.**

[Visit our Website](#)

[Menu]



[Go Back to Complete Lines](#)



www.emerito.com

Global Canning Expertise

info@emerito.com | Phone: +34 948 68 51 07 | Ctra. Mendavia – Logroño KM 0,5 – Mendavia, 31587, Navarra, Spain

